

22 INCH AWNING STEEL	LEFT	13.16.00.243
	RIGHT	13.16.00.244
22 INCH AWNING SST	LEFT	13.16.00.543
	RIGHT	13.16.00.544

ONE ARM ASSEMBLY AND ONE TRACK ASSEMBLY
REQUIRED TO MAKE A COMPLETE HINGE.

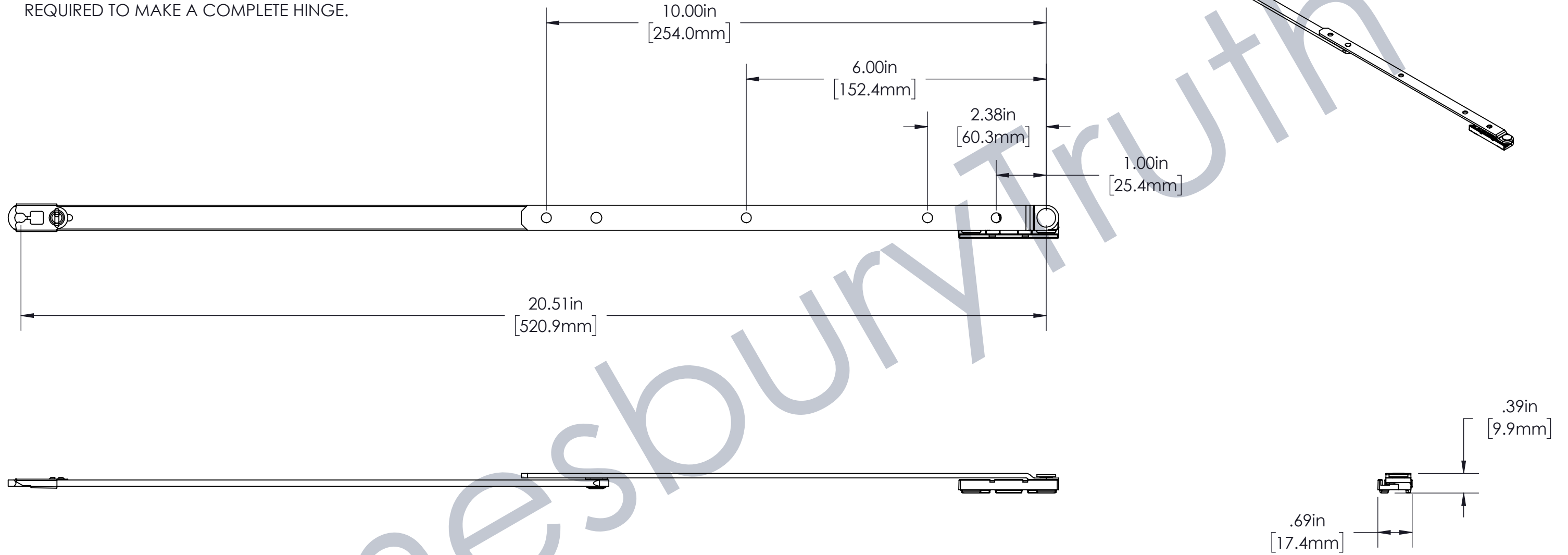

RECOMMENDED SCREWS:
(P/N 19110.XX) NO. 7 X .750 PHILLIPS FLAT HEAD SHEET METAL SCREWS (STEEL)
(P/N 19105.XX) NO. 7 X .750 PHILLIPS FLAT HEAD SHEET METAL SCREWS (STAINLESS STEEL)

FOR USE WITH TRACK ON PVC:
NO. 7 X .750 PHILLIPS FLAT HEAD UNDERCUT SHEET METAL SCREWS.
(NOT AVAILABLE FROM TRUTH, QUANTITIES DEPEND ON HINGE USED)
SEE TRUTH TIP NO. 5 & 6

CUSTOMER PAGE

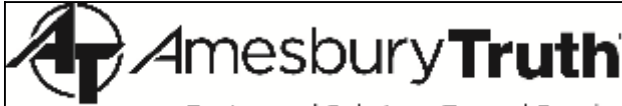
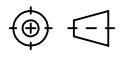
 Amesbury Truth Engineered Solutions. Trusted Results.	INTERPRET PER: ASME Y14.5M-2009 UNITS: INCH	DRAWING TITLE: 13.16.00.243 CUSTOMER PAGE KD 22 INCH ARMS LH
	THIRD ANGLE PROJECTION 	SCALE: 1:2 DRAWING #: 13.16.00.243

THE INFORMATION CONTAINED IN THIS
DRAWING IS CONFIDENTIAL AND PROPRIETARY.
THIS DRAWING IS NOT TO BE COPIED OR
REPRODUCED IN WHOLE OR IN PART WITHOUT
EXPRESS WRITTEN PERMISSION.